

# Fast Charging Solo 3 - Home Install Guide

This document details the install guidance for the Solo 3 (Home), a variant of the Solo product family. If you're unsure which model you have, please contact Pod Point directly.

The Solo 3 is designed for installations inside or outside, with the advanced safety systems we have built into the charger ensuring its safe usage. This guidance provides information to assist when installing the new Solo 3. This guide should not be used for any other EVSE.

Speed category	Fast Charging
Charging speed	3.6, 7 and 22kW models available
Product family	Solo



Tethered



Universal Socket

## Important safety information

The Solo 3 is designed and manufactured to be safe provided they are professionally installed, used and maintained in accordance with the manufacturer's instructions. They should be installed by approved electrical installers in accordance with national and local regulations applicable at the time of installation, e.g. BS7671:2018.

The Solo 3 is designed to be connected to one dedicated AC supply only. The property must comply with minimum BS7671 standards before installation commences and the supply must be adequately rated for the additional load required for EV charging.

As of the 1st January 2019 either a Type B or a Type A RCD with 6mA DC protection must be used for protection (6mA DC protection is included inside the Solo 3).

## Important notes:

A DC leakage fault in the vehicle may "blind" a type "AC" RCD and render it ineffective. BS7671 requires a "mechanical" RCD/RCBO that switches all poles (including neutral) be installed in the circuit and 2 pole isolation for RCD/RCBOs.

## Locations for install

The Solo 3 can be fitted inside or outside. The installer should consult the site owner to establish their preferred installation location. This should take into consideration the cable length (distance to vehicle being charged), risk of vehicle impact and obstruction of access etc.

IET code of practice recommends the Solo 3 be mounted to a permanent structure at a height of 750mm-1200mm (see Fig. 1). This is to assist those with accessibility requirements and reduce the risk of vehicle impact.

**Fig. 1 - Location and dimensions of the Solo 3.**



Universal socketed models consider the additional connector for the overall depth from wall when plugged in (approximately 150mm should be added).

## Technical details

The Solo 3 is a Class I/II rated device, pollution degree 3 for 230V / 400V AC 50Hz systems and is IP54 and IK10 rated.

It is designed to meet the following European standards: BS EN IEC 61851-1:2019 (BS7671 722.511.101), Low Voltage Directive (LVD) 2014/35/EU and electromagnetic compatibility (EMC) Directive 2014/30/EU. Sockets and EV charging connectors comply with IEC 62196-1.

During manufacture, each Solo 3 has been functionally tested for safety using BS EN 61010 and BS EN 61557 approved equipment.

### IEC 61851: (6.3.2 Optional functions)

The Universal socketed Solo 3 includes an electro-mechanical means for locking Type 2 connectors (as per IEC 61851-1, IEC 62196-2 and BS7671).

The Solo 3 does not support (State D) ventilation for lead acid battery vehicles.

All Solo 3s include overcurrent protection for the various charging cables that may be used.

## Earthing arrangements

The Solo 3 EVSE includes a safety monitoring system to detect low voltage supplies, failed earths and potential earth-neutral faults. If a fault condition is detected, the charge cycle is ended or prevented and the Solo 3 effectively becomes a double insulated (Class II) device and isolates the vehicle from supply and earth.

This feature removes the requirement for an earth electrode where it may be ineffective or introduce further risk. The Solo 3 (Tethered or Universal socketed) may be connected directly to a TN-C-S (PME) earthing system without any special arrangements and complies with regulation 722.411.4.1 (v) of BS7671.

### Get our technical advice on earthing:

See our earthing arrangements information sheet - find it on our [installation documents page](#). Scan the QR code to get there with your smartphone.



## RCD protection:

From January 2019, all Pod Point chargers include 6mA DC vehicle fault protection and only Type A RCD/RCBOs are required at source.

If the Solo was built earlier than January 2019, Type B RCD protection should be fitted; the symbols printed on the RCD in Fig. 2 can be used to identify the type of RCD protection. Care should be taken if using pollution degree 2 devices if located outside.

**Fig. 2**  
RCD Markings

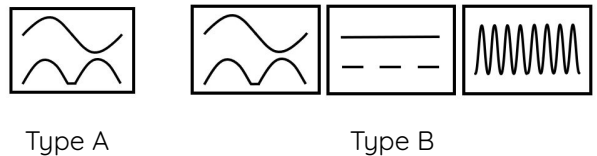

The RCD may include additional markings.

### Notes:

A vehicle DC leakage fault can “blind” certain type “AC” RCDs.

## Surge Protection Devices (SPDs):

See BS7671: section 443 guidance.

The Solo 3 includes Type 3 protection against transient over voltages (+/-2kV Line-Earth and +/-1kV Line-Line as a requirement of EN 61000-6-1). The guidance on risk calculation in section 443.5 in most cases is difficult and it may be prudent that Type 2 protection should be installed at the source of supply, especially if life support equipment or business operations could be affected. Type 1 SPD may also be desired in certain higher risk locations.

### Notes:

EU homologated battery electric vehicles do not have the ability to create AC supply voltage spikes under normal circumstances. SPDs have a finite life expectancy and may require replacement in as little as 1 year. Frequent checks of the SPD's health indicator is advised.

## Transformers

If a galvanically isolated transformer is required, it should be placed upstream of the EVSE. The neutral output feed of the transformer should be connected to EVSE earth (creating a TN-S system) and the PE taken before any RCD and MCB (if 2 pole MCB is used). Resistance measured between the EVSE earth and PE Earth must be less than 100 ohms. Do not connect the output earth/neutral of the transformer to a PME earthed system. Upstream transformer RCD protection may be of Type AC (if fitted). Downstream RCD protection is still required. Transformers should be rated for 100% duty cycle at 10% above rated charge current.

- Transformers should be located in a dry and well ventilated area.
- Transformers shall comply with the requirements of IEC 61558-1 and IEC 61558-2-4.
- Direct EVSE connection of an EVSE to a three-phase IT system is prohibited. Contact us if an IT network is to be used with a single-phase Solo 3 as it will report an earth fault.

## Isolation and switching for security, safety and maintenance

To ensure that the Solo 3 can be “turned off” and to enhance security and enable maintenance activities, a double-pole isolator suitably rated must be installed within the circuit (2-pole RCBO can provide isolation).

An additional isolator switch may already be provided in a new build, but is optional for existing dwellings (at customer’s request and cost). The isolator should be mounted at a height of between 500mm and 1500mm above finished floor level to comply with regulations. The switch should be rated greater than 32A.

Any devices located outside should comply with pollution degree level 3 for safety and reliability.

Installation of any accessory devices must also comply to relevant BS7671 regulations.

## Installation procedure

**Note:** national or local regulations not related to electrical works are not covered in this guide. Relevant H&S at work, building regulations etc. must be adhered to.

Prior to any installation work beginning (drilling or fitting of conduit and cables etc.), allow the customer to visualise where the EVSE will be installed. Consider cable trip hazards and access routes. Once the customer has confirmed the location meets their expectations, the location may be marked up and installation can commence.

### **Non-permanent structures must not be used to fit the EVSE to, e.g. fences and trees.**

The installer should confirm the wall that the EVSE is intended to be fixed to is structurally appropriate for the mounting of the unit and identify the correct and appropriate fixings to be used.

- The Solo 3 must be securely attached to the wall or other “permanent” structure where it is intended to be operated from.
- To maintain IK10, at least 80mm long screws should be used for brick or concrete and it is recommended penny washers be included.
- Before drilling commences, ensure that the installation wall has been checked for electric cabling or pipework with a suitable detector.

Once the location and height of the Solo 3 has been decided, the installer can begin marking the wall with indicator points to locate the unit. Use the box insert as the drilling template for the 3 mounting holes (Fig. 4).

**Notes:** If any groundworks are required (cable trenching or earth electrode fitment) it is advisable to check if underground services could be present before commencement. Plans for undergrounds services may be available at: [linesearchbeforeudig.co.uk](http://linesearchbeforeudig.co.uk)

## Drilling the holes for the electrical supply cable entry

The unit has been designed to accept supply cable entry on either the left, right, bottom or via rear. Top entry is only possible if there is no risk of water ingress (indoors). The installer should drill a suitably sized hole for the cable and suitable gland to be used. Entry holes should only be drilled on flat surfaces as shown.

Fig. 3

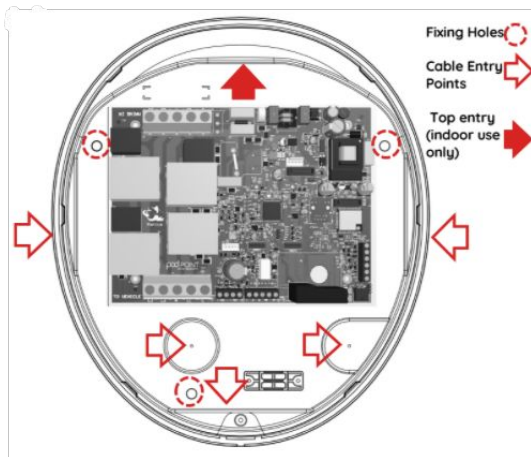

When drilling the case:

- Do not drill holes on any curved face.
- Take care not to damage any wiring or components inside the case. Place a suitable stop (e.g. block of wood) inside the case when drilling to prevent accidental damage.
- If any of the wiring or components are damaged during installation **DO NOT CONNECT OR SWITCH ON THE POWER** before consulting with Pod Point.

The wall can now be drilled for the 3 fixing holes. **Do not drill with the Solo 3 in position as masonry dust may cause latent damage.**

Once the holes are drilled and plugged, the Solo 3 can be securely fixed to the wall.

**Note:** the surface should be reasonably flat; stone walls may not be suitable without additional preparation.

Fig. 4 Drilling template (box insert)

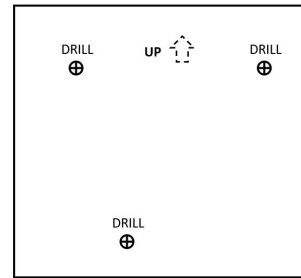

## Wiring up the Solo 3

The supply cable used should be rated for a maximum current of at least 33A for a 7kW Solo 3 and should be approved to British Standards.

- With the rear of the Solo 3 securely fitted to the wall, the electrical supply connection can be made.
- The installation route of the wiring will vary with each installation. Allow adequate cable length inside the Solo 3 for easy termination, avoiding stress to the cables and PCB. To avoid cable interference do not route cables over the PCBA on Universal socketed Solo 3s as this will prevent the cover with socket from fitting correctly.
- The choice of entry point used will determine the amount of insulation/SWA that needs to be removed for the internal wiring connection of the Solo 3. Fig. 5 illustrates the connection terminals for the supply cables.
- When cutting SWA cables, allow at least 10mm of inner insulator to enter the Solo 3's housing to avoid cores "chafing" with the gland or SWA.

All cables that are to be connected into the supply terminals should have their insulation stripped back, exposing 12-15mm of copper conductor to ensure good contact in the screw terminal jaws and insulation is not "clamped".

Torque settings for supply input connections are 1.5-2.0Nm. Appropriate pull tests shall be performed after tightening connections to confirm they are correctly clamped into the terminal block.

## Solo 3 Supply Wiring

**NOTE:** There are variations of the Pod Point EVSE main PCBA. Check markings at the connectors to ensure the correct terminals are used.

**THE LAYOUT OF THE PCBA MAY BE SUBJECT TO CHANGE WITHOUT NOTICE.**

- Ensure that incoming cables are connected to the appropriate terminal depending on PCBA variant - PCBA connector labelling must be followed.

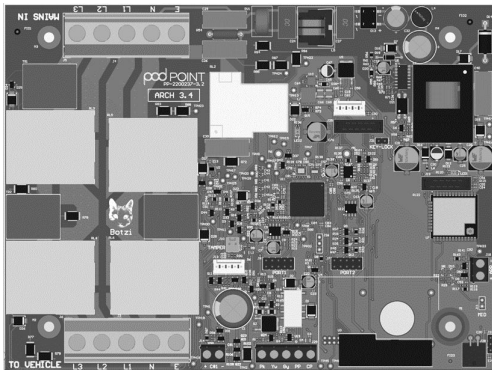
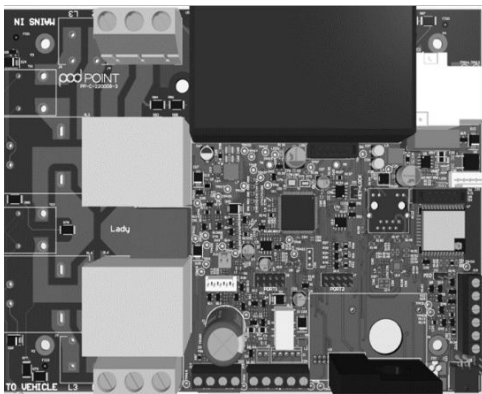

Fig 5. PCBA Variant Examples

## Supply input cable wiring

Live 1:	Brown
Live 2:	Black
Live 3:	Grey
Neutral:	Blue
Earth:	Green/Yellow

## Screened cable

Signal (usually red)  
Screen (outer braiding of cable)

## Auto Power Balancing (Load balancing)

The Solo 3 provides a load curtailment feature where additional uncontrolled loads of EV charging could potentially overload the supply.

The default supply limit is set by default at 60A. This can be changed either locally by connecting to the PCBA Wi-Fi and opening the page **192.168.101.1** or remotely when connected to Wi-Fi by contacting Pod Point customer support to change this value.

## Wiring of the Energy Clamp

The current transformer used for Auto Power Balancing on a domestic supply should be wired using a screened cable to eliminate the risk of noise affecting charging rates.. The Solo 3 should be wired to terminals as shown. The screen or “braiding” of the signal wire should be connected to the GND(-) terminal of the blue screw terminal block **J14 C#1**.

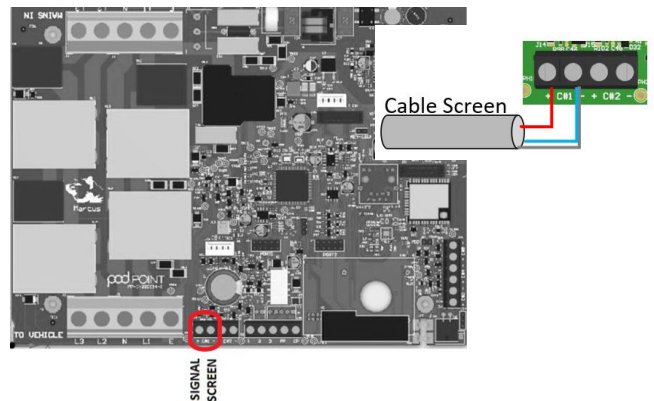

FIG.6 Energy Clamp Connection points to PCBA at J14 C#1 (Double Connector Arrangement)

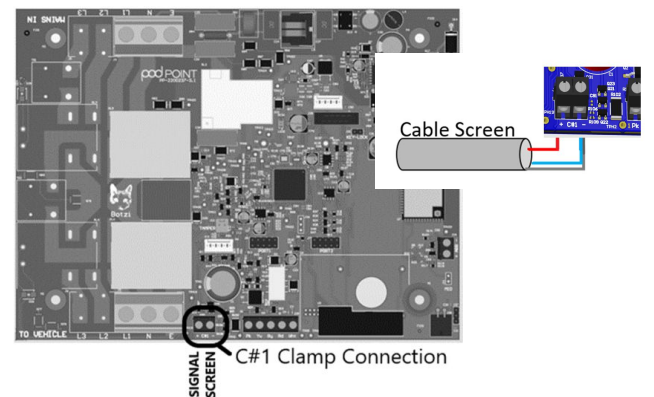

FIG.7 Energy Clamp Connection points to PCBA at J14 C#1 (Single Connector Arrangement)

**Note:** Terminals require no more than 0.5Nm of torque; overtightening of these terminals can sever the cables and also damage the terminals.

## External Current Transformer (CT) fitting:

The CT should be clamped around the incoming supply feed. If PV or a storage battery is also in use the “feed in” load from these should be avoided if possible. Only the domestic and Solo 3 “loads” should be measured by the CT.

Where the only available supply cable includes PV or storage “export” energy, contact Pod Point to configure the Solo 3 to work with these.

## External Current Transformer orientation

The “split core” transformer has a direction arrow marking inside. This should be fitted in the direction of the incoming live. If fitted to Neutral reverse the direction of travel (for single-phase supplies only).

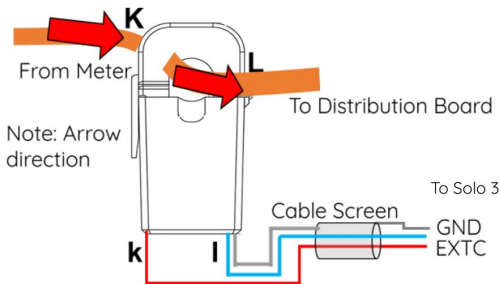
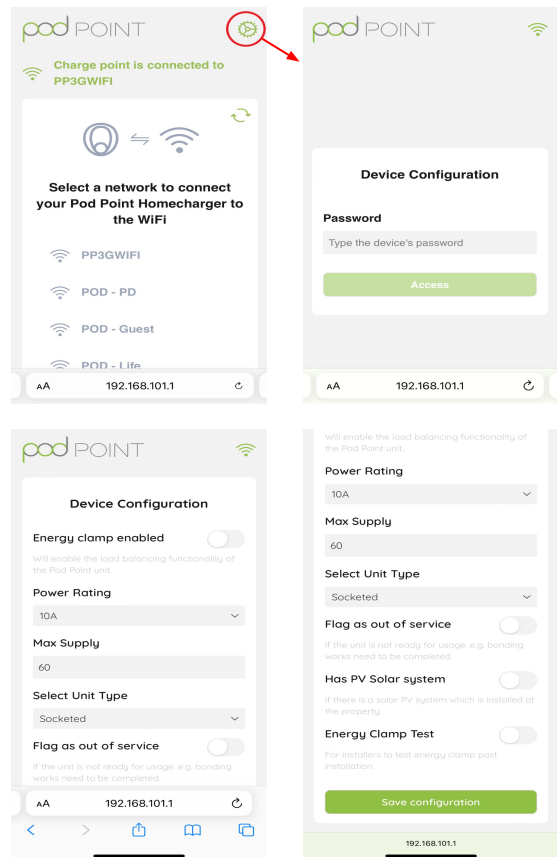

**Fig. 8 Energy Clamp Orientation**

## Setting up the Solo 3.

Current rating, cable overcurrent protection and load curtailment settings must be set before testing and final assembly of the Solo 3.

Connect to the *podpoint* AP and configure the Solo 3 by going to **192.168.101.1** Press the cog in the top right corner and enter the password which can be found in this section of the in-box install guide.



## System wiring

Typically an additional small consumer unit will be fitted as few existing distribution boards support a 3rd split load required for EVSE. When this additional unit is installed, a screw terminal junction box(es) should be installed at the incoming supply to avoid any modifications to the existing consumer unit. If there are any safety concerns regarding the existing board, the customer should be made aware.

## Do not use IDC terminals for the installation.

If a consumer unit includes a spare non-RCD protected circuit, this may be used to supply the additional “mini” consumer unit. Use recommended torque settings for all MCB, RCD and terminal blocks.

## Supply Cable

The size of the supply cable used should be designed for a maximum current of 33A (7kW Solo 3) and be approved to relevant standards.

**Fig. 10 Typical Solo 3 installation layout.**

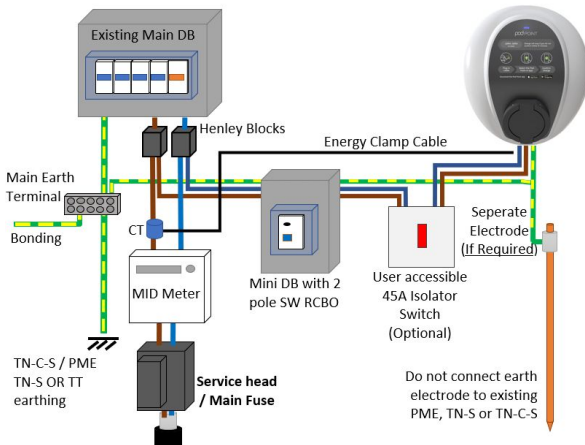

## Final electrical testing

To meet the requirements for testing of an electrical installation:

- Visually check the installation, including the existing electrical installation for any issues.
- Check the condition of any existing bonding; if any issues are found, correct if possible or advise customer if the work is too far out of the scope of the installation.
- Verify the characteristics of the electrical supply at the origin of the installation to confirm its suitability for the additional load.
- Check the service head and cables are serviceable and advise as necessary if issues are identified.
- Check for exposed cables and ensure any missing blanks are replaced.
- Confirm the new circuit insulation resistance.
- Confirm the polarity of the installation is correct.
- Where applicable, confirm that the earth electrode resistance is within acceptable tolerances.
- The mechanical operation of the residual current device, including the rated trip current and at five times the rated current.

- A test or calculated measurement of the prospective fault current.
- Functional verification using an EV simulator confirming operation of the Solo 3.
- If a vehicle is available, check the vehicle charges normally for a short time.
- If the Pod Point EV simulator is available, test fault state and DC 6mA functions of the Solo 3.

**Note:** At the time of this document's publication, there are no specific standards for 6mA DC testing. If ramp tests are conducted, false readings are possible if the test equipment has too fast a ramp up time.

When checking internal safety systems of the Solo 3, disconnection of the vehicle/tester may be required to reset these systems.

## Energy Clamp Testing

If relevant connect the Energy Clamp to **C#1** and measure the resistance between the positive and negative terminals. The resistance should be around 74 ohms. If less than 10 ohms you have a short circuit, if greater than 80 ohms you have an open circuit between the PCB and the Energy Clamp.

To enable Energy Clamp test mode visit the AP webpage **192.168.101.1** and toggle 'Energy Clamp Test' on and lastly save configuration.

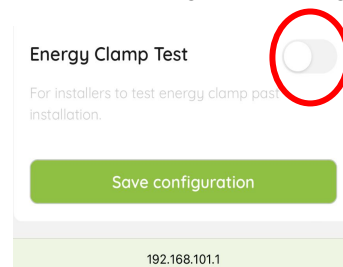

1. Disconnect the Energy Clamp from the tail or from the connector on the PC
2. Plug the Pod Point EV simulator into the Solo 3 and the heater into the EV simulator socket.
3. In state C the Solo 3 should fault if the Energy Clamp is operating correctly.
4. To conclude this test access the AP webpage, disable 'Energy Clamp Test' and save the configuration.
5. Reconnect the Energy Clamp and ensure the Solo 3 does not fault in State C.



## Energy Clamp Test Troubleshooting

If an error occurs when charging follow the steps below:

1. Check that the Energy Clamp is in the correct location
2. Check that the Energy Clamp is “closed”
3. Check that the Energy Clamp is correctly wired
4. Check if the customer has solar panels that the PV setting has not been turned on (contact Pod Point to update if not)
5. Unclip the Energy Clamp, so as not to measure current and proceed to a resistance check at GND/EXTC terminals to confirm the correct wiring:

If an error still occurs, it’s likely to be a faulty clamp (the ferrite cores can be broken if the clamp is dropped or mishandled).

If a clamp “buzzes” check it is clipped “shut” and/or check the resistance is correct (~70 ohms). Current transformers with no burden load can buzz.

## Connecting the Solo to Wi-Fi

Visit [Pod Point’s Installation documents webpage](#) to get to our *Pod Point Solo Wi-Fi Connection Guide*

Scan this QR code to get to our installer documents webpage - you’ll find the connection guide here.



On power up of the Solo 3, the front LED should illuminate white. To connect the Solo to a Wi-Fi network do the following:

- Search for “podpoint” Wi-Fi network on your mobile device and connect to it.
- On the device’s web browser address bar type **192.168.101.1** then “Enter” or “OK”.
- A page displaying available networks should show. Select the desired network and enter the network password. Press “Connect” at the bottom of the page.

**Note:** The page will remain displayed but inactive after “Connect” has been pressed.

- Wait for 1 minute. The LED should change to blue with a short pink flash when it has connected.
- If the status LED remains white, you may need to restart the Solo 3 again and verify the settings (see notes at end of this guide).

## Fitting the front of the charger

Once the wiring, testing and setup of the Solo 3 is completed, the front cover can be fitted in place.

Prior to fitting the front cover, visually check the internal wiring will not interfere with assembly, dress if needed, and remove any debris that may have entered during installation.

Check that the front cover mating seal is in place before fitting the cover to the housing. The front cover can then be secured in place using the 6 screws.

## Accessories, features and helpful hints

### Remote diagnostics

When connected to the internet via Wi-Fi, the Solo 3 will provide information on supply voltage(s), status of the incoming earth, charging current, temperature, rating of connected cable, etc. This data is primarily used for internal diagnostic purposes but is also used for energy usage displayed in the Pod Point App. In exceptional circumstances, Pod Point may contact the site/charger owner if an abnormality is detected.

### Key lock

The Solo 3 may include a mechanical key lock feature to disable use of the charge point where theft of electricity is a concern. The key lock input requires “volt free” isolated switching contacts. When the contacts are closed, the Solo 3 enters a “Pause” state and the LED will flash yellow.

### Theft of the Solo 3

All Solo 3s include a unique MAC address to identify itself which is programmed into the silicon and cannot be changed. If a Solo 3 is reported as stolen and its connection to the Pod Point network is attempted, it can be placed permanently out of service.

## Troubleshooting Wi-Fi connection problems

Sometimes, Wi-Fi routers block the connection of devices for various reasons. These may be related to the total number of connected devices, bugs in the router's ARP table, password errors and other system settings.

If it is known the correct network and password have been entered (the device used for setting up may "capitalise" the 1st password character etc.) and the Solo 3 fails to connect after it has been restarted, a restart of the Wi-Fi router may cure the issue. The router should refresh the ARP table if conflicts existed.

Solo 3s support 802.11 bgn Wi-Fi networks. AC is not supported. Ensure 2.4Ghz Wi-Fi is enabled on the router.

Check to make sure the default router password has not been changed and is no longer than 15 characters.

Check the security settings on the router have not been changed. Solo 3 EVSE use WPA2 by default.

Check the router's settings have not been modified to limit the number of users it will allow to connect.

Some low cost Wi-Fi routers have a maximum limit of connected devices they can support. If possible, remove a device from the network and retry.

If a managed IT network is in use, the addition of the Solo 3 using the MAC address may be the only option. The MAC address can be provided by Pod Point from the PSL number of the Solo 3 which can then be included in the router's "allowlist".

Some Technicolour routers will only allow connection after the Solo 3's MAC address is added to the allowlist. After adding this, the Solo 3 can be added in the usual way.

The Solo 3 cannot connect to networks that require an email address or where Terms and Conditions need to be agreed.

## Cable and adaptor warning

IEC 61851-1 dictates that in-cable adaptors must be approved by the vehicle or the chargepoint manufacturer. In the interest of safety, Pod Point do not approve the use of any in-cable adaptors for customer use as they can and do override safety features.

Adaptors/cables that change operational states of the EVSE are forbidden under terms of IEC 61851-1. These cables (commonly used for energy management) are not approved. Bypassing fundamental safety systems of the Solo 3 can compromise electrical safety.

Charging cables cannot be used as "extension" leads; the "CP" pin is intentionally made shorter to prevent this.

It is prudent to visually check both plugs and sockets on any equipment for damage or debris before every use. Ensure all connectors can be fully plugged into the vehicle and chargepoint before use. Vehicle, cable or chargepoint manufacturers may not cover damaged cables under terms of their warranty.

## Commissioning of the Solo 3 to validate the warranty

It is important that all Pod Point EVSE is commissioned once it has been installed. Failure to do so will mean the EVSE is not covered by warranty, and the end user will not be able to access the charging point via the Pod Point App.

### Commissioning of domestic Solo 3 chargers:

To commission a domestic Pod Point charger please complete the commissioning form at:



[podpoint.force.com/commissioning/s/login/](https://podpoint.force.com/commissioning/s/login/)

For more information about domestic Pod Point commissioning:

[pod-point.com/products/installer/domestic-install-training](https://pod-point.com/products/installer/domestic-install-training)



## Testing of functionalities

Ensure the front cover is securely attached prior to turning the power on. This will prevent activation of the tamper detection which will prohibit further testing and be visible by the presence of a red flashing yellow light sequence.

When power is turned on, the lights on the Pod Point Solo 3 should change colours as follows:



1. **Establishing communication with server** (takes up to 1 min) - white



2. **Communication established, car not plugged** - blue flashing pink

An EV simulator is required for functionality tests.



1. **Unlock mode** - blue/flashing pink



2. **Standby** - Flashing green



3. **Charge** - Green



4. **Fault** - Solid or flashing red

If the test procedure fails at any stage please contact Pod Point.

## Customer support - Help Centre

If you need more help, our online Help Centre covers a range of topics for installers and customers, including how to connect the Solo 3 to Wi-Fi, how to commission Pod Point chargepoints, and various troubleshooting guides and tips.

Visit the Help Centre using this link:  
[help.pod-point.com/s/](https://help.pod-point.com/s/)

